

# GAS VALVE SYSTEM

Due to the latest rules and regulation following MARPOL Annex VI, NO<sub>x</sub> and SO<sub>x</sub> ship exhaust gas will be reduced heavily. The updated emission requirement resulted in various developments like scrubber and fuel gas supply systems.

AC-INOX has a proven running fuel gas system capable to supply the ME-GI engine with 400 bar of methane and ethane fuel. Within this development AC-Inox started to integrate additional supplement systems to improve the system overall reliability and availability.

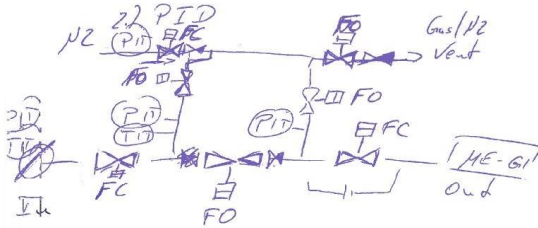

From idea...

AC-INOX designed the world's first **Gas Valve System (GVS)** that is covering fuel supply with an operating pressure to 420 barg / 2500 lbs and an operating temperature of -50°C up to +125°C.

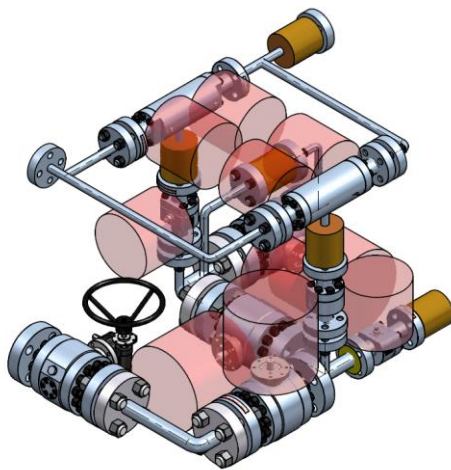

...through concept study...

Besides, the GVS is able to operate on all combinations of LNG / LEG / LPG and H<sub>2</sub>. Furthermore it is compatible for fuel gas supply without requiring any hardware changes. Thanks to the AC-INOX unique design of the low torque valves, it is possible to use size optimized actuators. The compact construction of the GVS allows an easy monitoring and control of the GVS functions. Additionally, a complete stand alone GVS will be provided and can be integrated into the main Fuel Gas Supply System.

The protection of the main engine through the GVS is ensured with the mean of pressure and temperature measurements and fuel filtration.

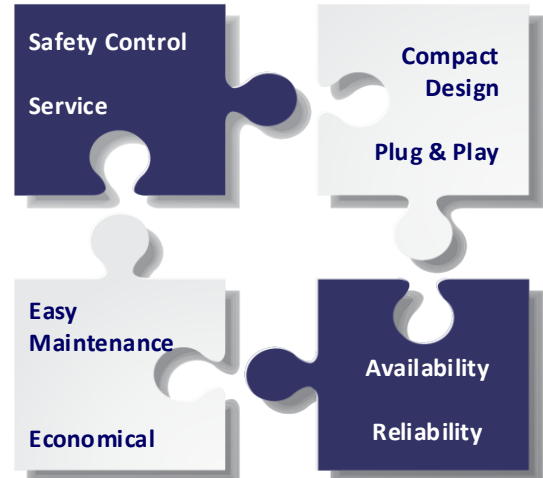

Nevertheless, the simple construction concept of the GVS makes its maintenance straightforward and economical.



...into reality!

...we serve for your safety!